



NAMIBIA UNIVERSITY
OF SCIENCE AND TECHNOLOGY



Regenerative Biomass Utilisation by Transdisciplinary Applied Research and Technology Development in Namibia

Mr Evert Strydom

Faculty of Engineering

Namibia Biomass Symposium, 21 - 22 November 2019

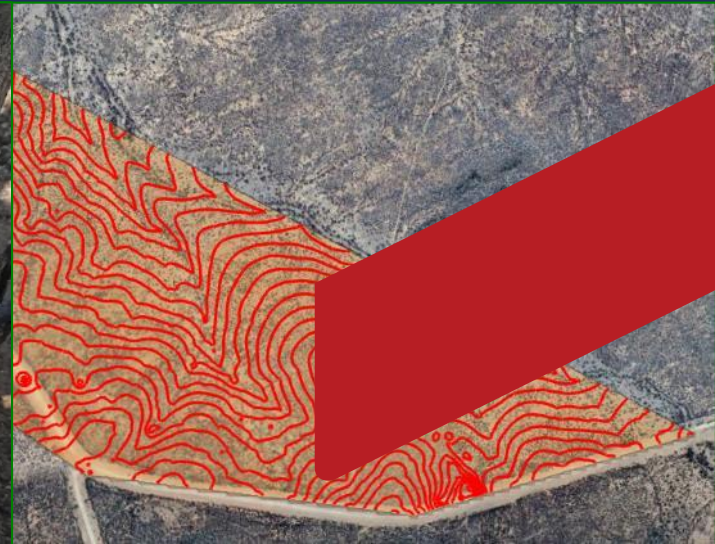



Contents

1. Introduction & Definitions
2. BUSH Project Overview
3. Manual Bush Control Progress
4. Transdisciplinary Research Approach
5. Conclusion



No Cattle = No Bush Problem





NAMIBIA UNIVERSITY
OF SCIENCE AND TECHNOLOGY

Namibia Biomass Symposium 21 - 22 November 2019



BUSH

BIOMASS UTILISATION BY SUSTAINABLE HARVEST



Plasser & Theurer





Radish Bioassay

Deliverable: to source and test 10 different biochars conditioned by charging with nutrients and/or inoculating with beneficial microbes

Honours project by Ms Mirjam Namangudu. Initial testing will be done in bags to determine effect on radish growth and quality over a month





Radish Bioassay

Factor 1: Species/type of Feedstock and Method of Production



CoW Woodchips



TLUD



Common Drum Kiln



Kon-Tiki
Kiln



Small Retort



Large Retort





On-farm Trial

Deliverable: to test and report on biochar's impact on farming field's productivity/yield, by Masters student Helmi Auala

The results from the Honours project bioassay will be used for selecting appropriate biochar type and conditioning, for testing on growth of irrigated lucerne in a newly cleared field of 50 x 20 m at Humulus Farm





N
OF

er 2019



BUS



Objective

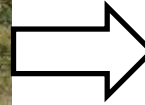

WPCs Production Circle





BUSH Current Project Types

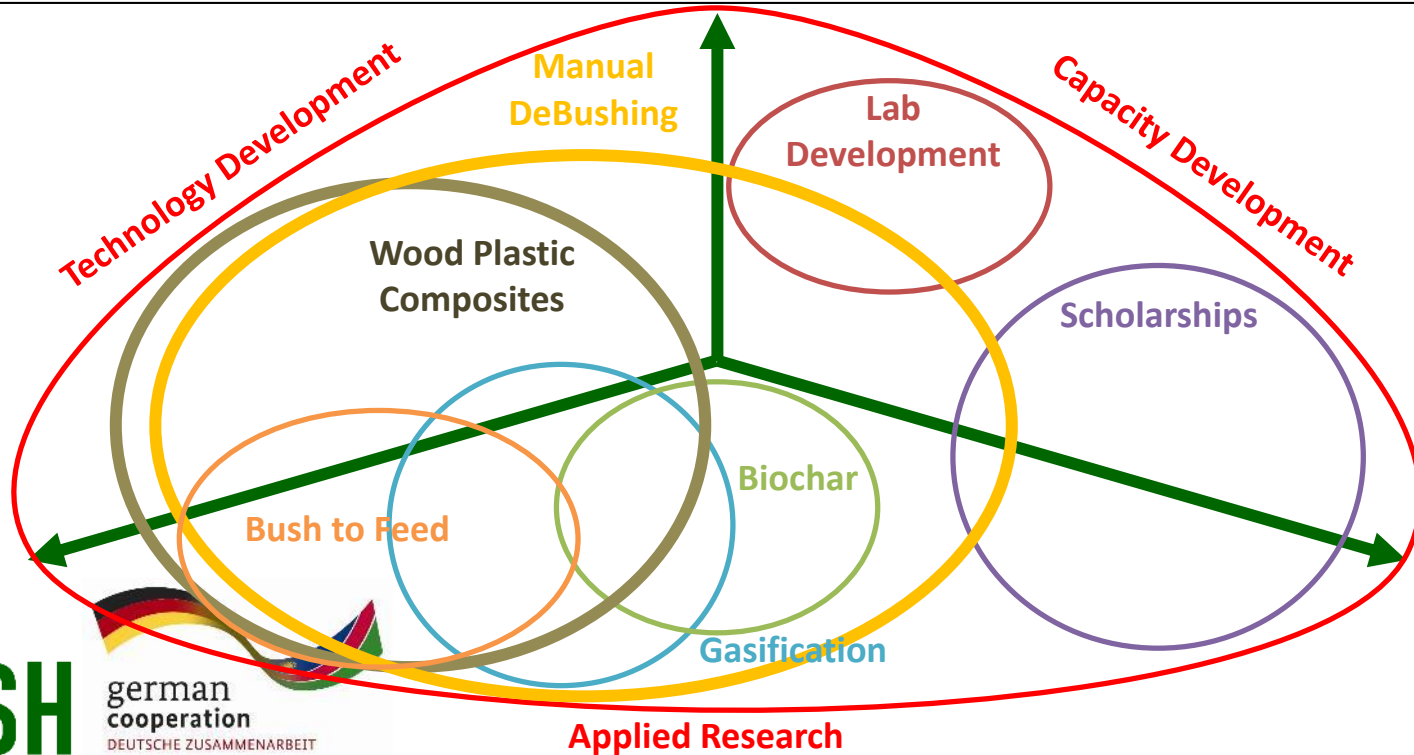



BUSH Current Project Types

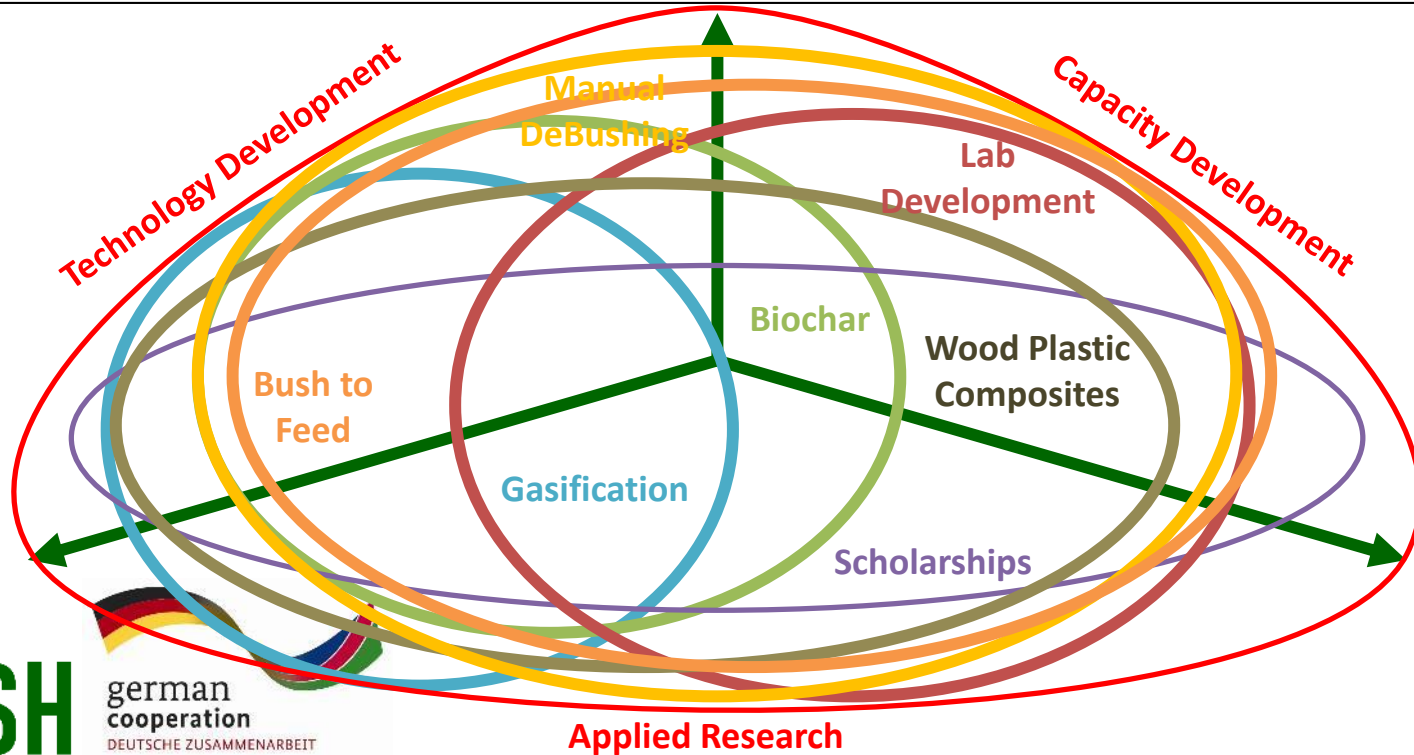

BUSH Possible Future Scope??

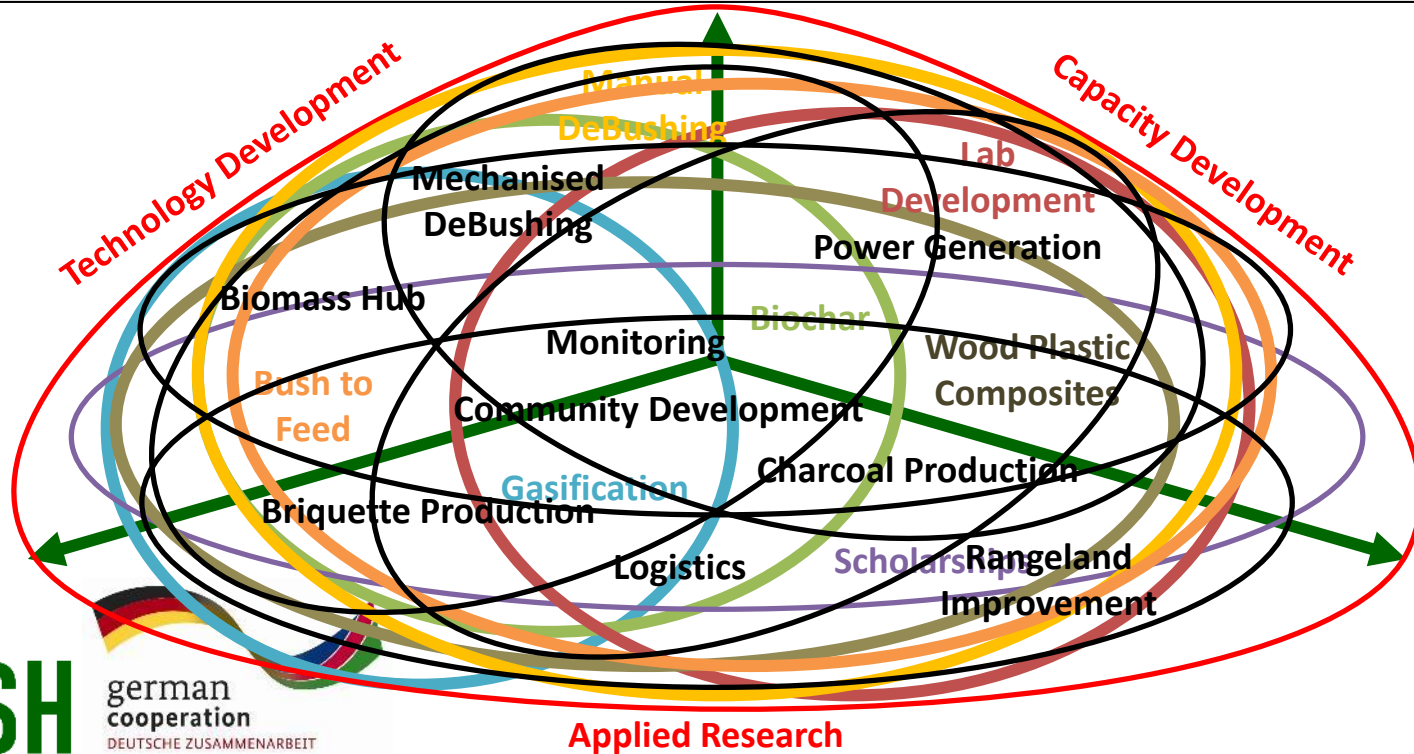



3. Manual Bush Control Research





Bush Control by Jobs

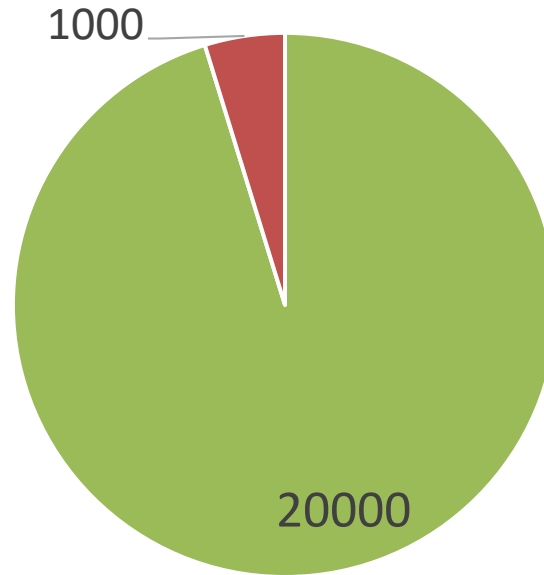

■ Manual ■ BullDozer





Bush Control By Area

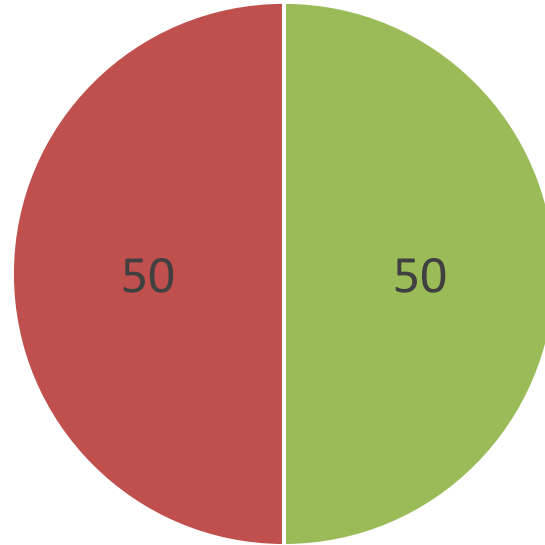

■ Manual ■ BullDozer



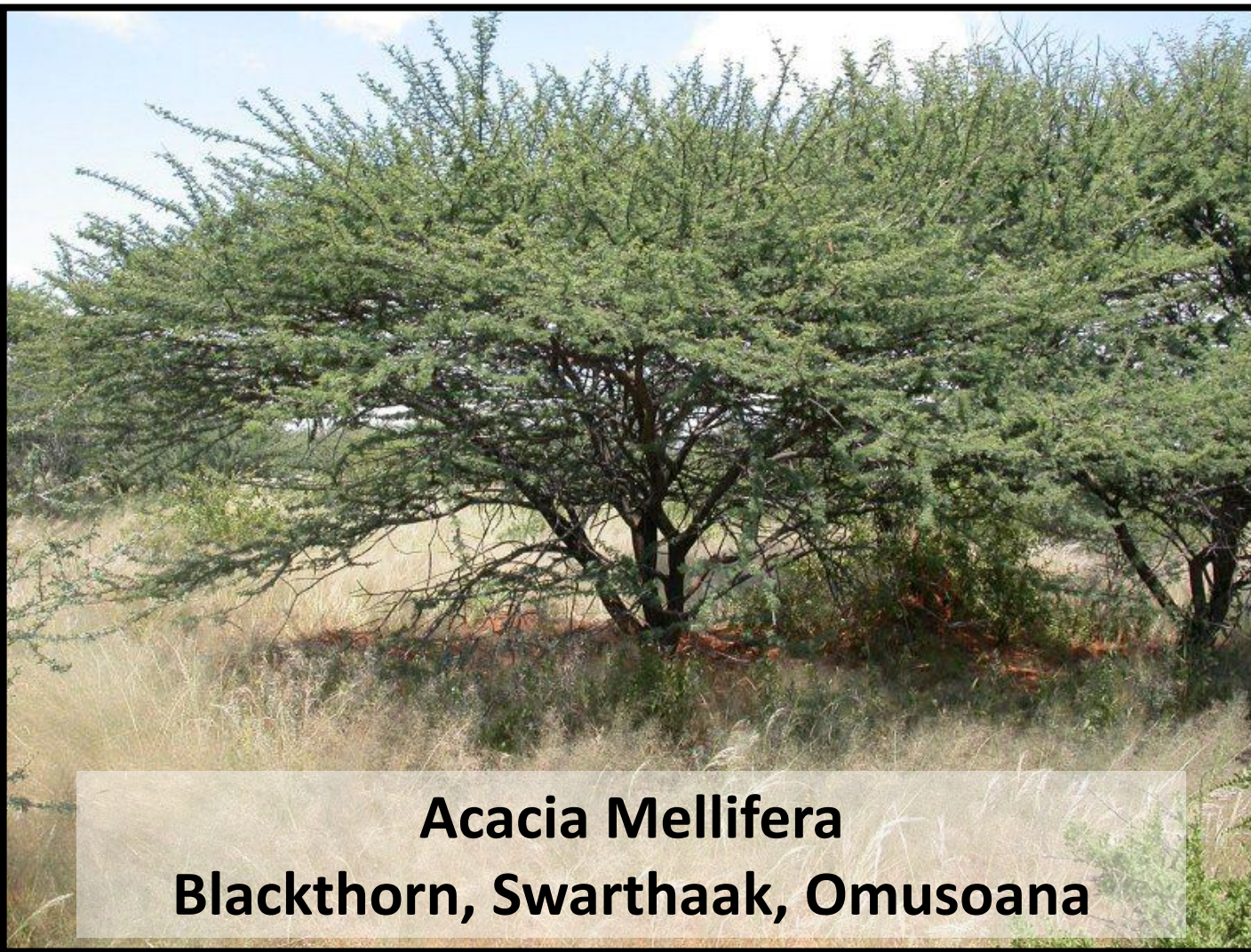

Acacia Mellifera
Blackthorn, Swarthaak, Omusoana



Acacia Mellifera
Blackthorn, Swarthaak, Omusoana









Energy Transfer Efficiency = f (human, tool, bush, climate)

$$\eta_{HET} = f(Q_h, Q_t, Q_b, Q_c)$$

where:

$$Q_h = f(\text{posture, fatigue, experience})$$

$$Q_t = f(\text{sharpness, profile, balance})$$

$$Q_b = f(\text{species, branches, angle})$$

$$Q_c = f(\text{season, rainfall, soil})$$





	PO	Fatigue	E	SH	PR	BA	SP	BR	SE	A	
PO		+++				-					4
F	---			-		-					5
Experience	+++	---		+++	+++	+++	+++	+++			21
SH	-	---									4
PR		---		-							4
BA	-	---		-							5
SP	+++	+++									6
BR	+++	+++				-					7
SE		+++		-							4
A		+++		-							4
	14	27	0	8	3	6	3	3	0	0	





1st Prototype





2nd Prototype

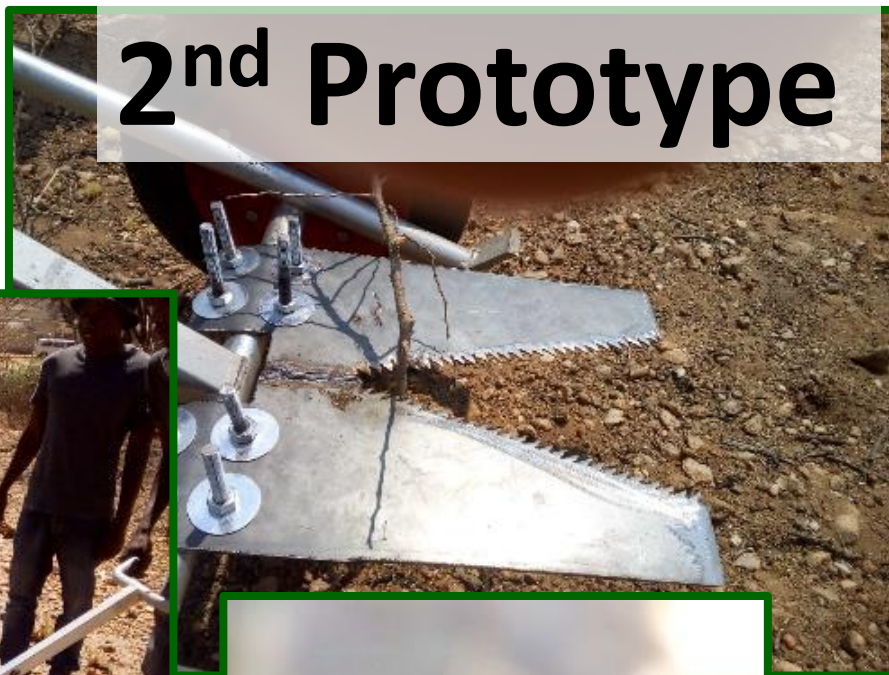



3rd Prototype





4th Prototype



5th Prototype



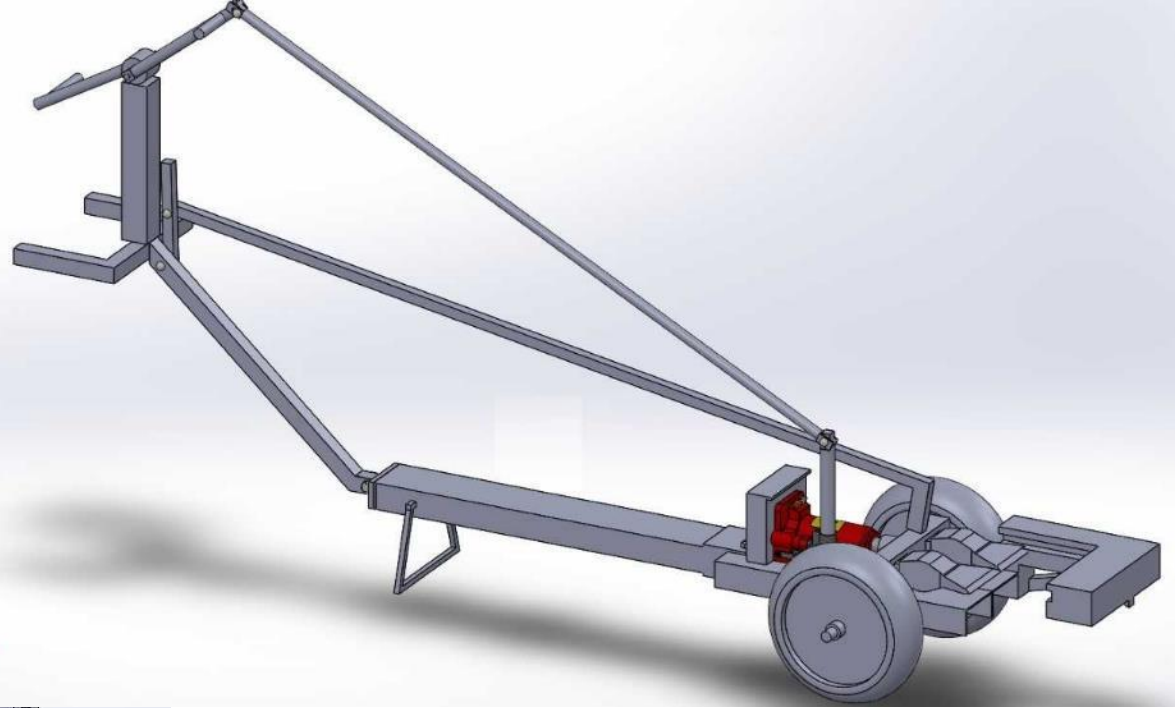
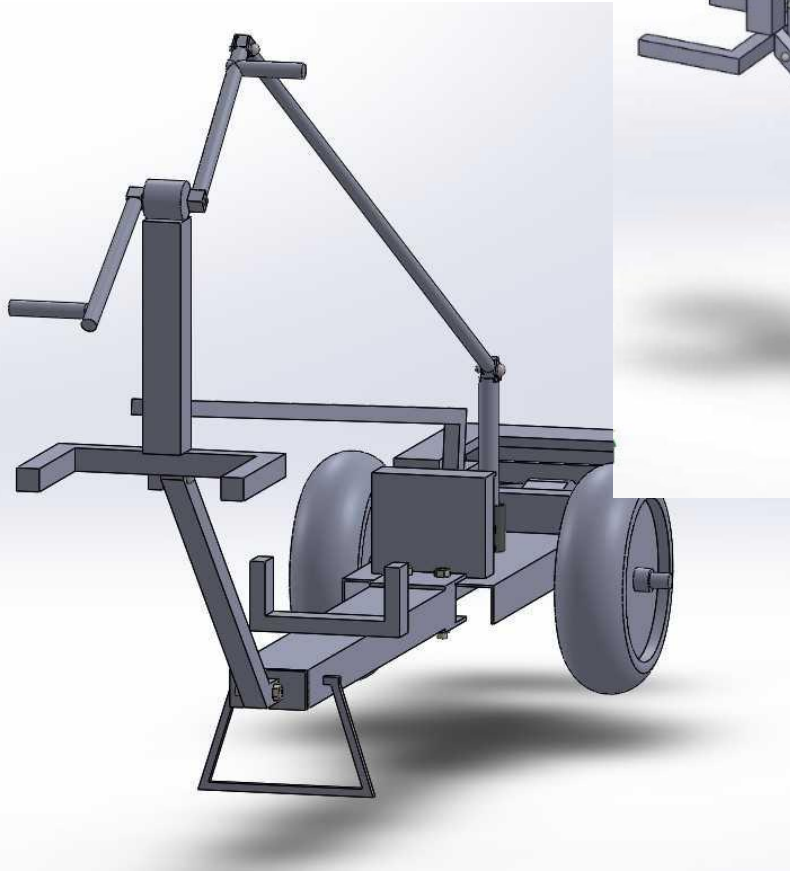

6th Prototype



NAMIBIA UNIVERSITY
OF SCIENCE AND TECHNOLOGY

Biomass Utilisation by
Sustainable Harvest
(BUSH) Project



BUSH

A Research and Technology
Development Initiative funded
by the GIZ



german
cooperation
DEUTSCHE ZUSAMMENARBEIT

bush.nust.na



NAMIBIA UNIVERSITY
OF SCIENCE AND TECHNOLOGY

Biomass Utilisation by
Sustainable Harvest
(BUSH) Project



BUSH

A Research and Technology
Development Initiative funded
by the GIZ



german
cooperation
DEUTSCHE ZUSAMMENARBEIT

nust.na

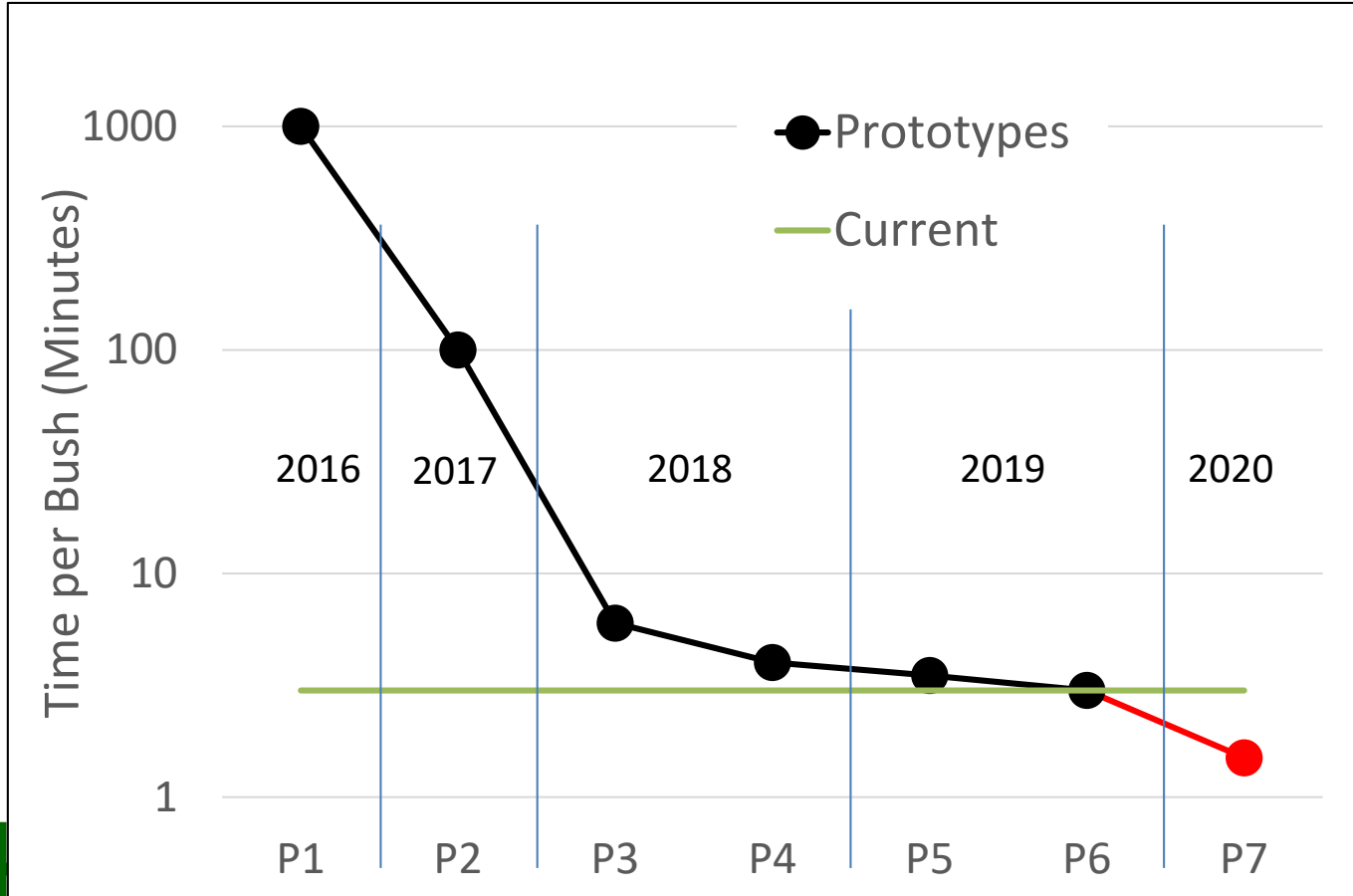

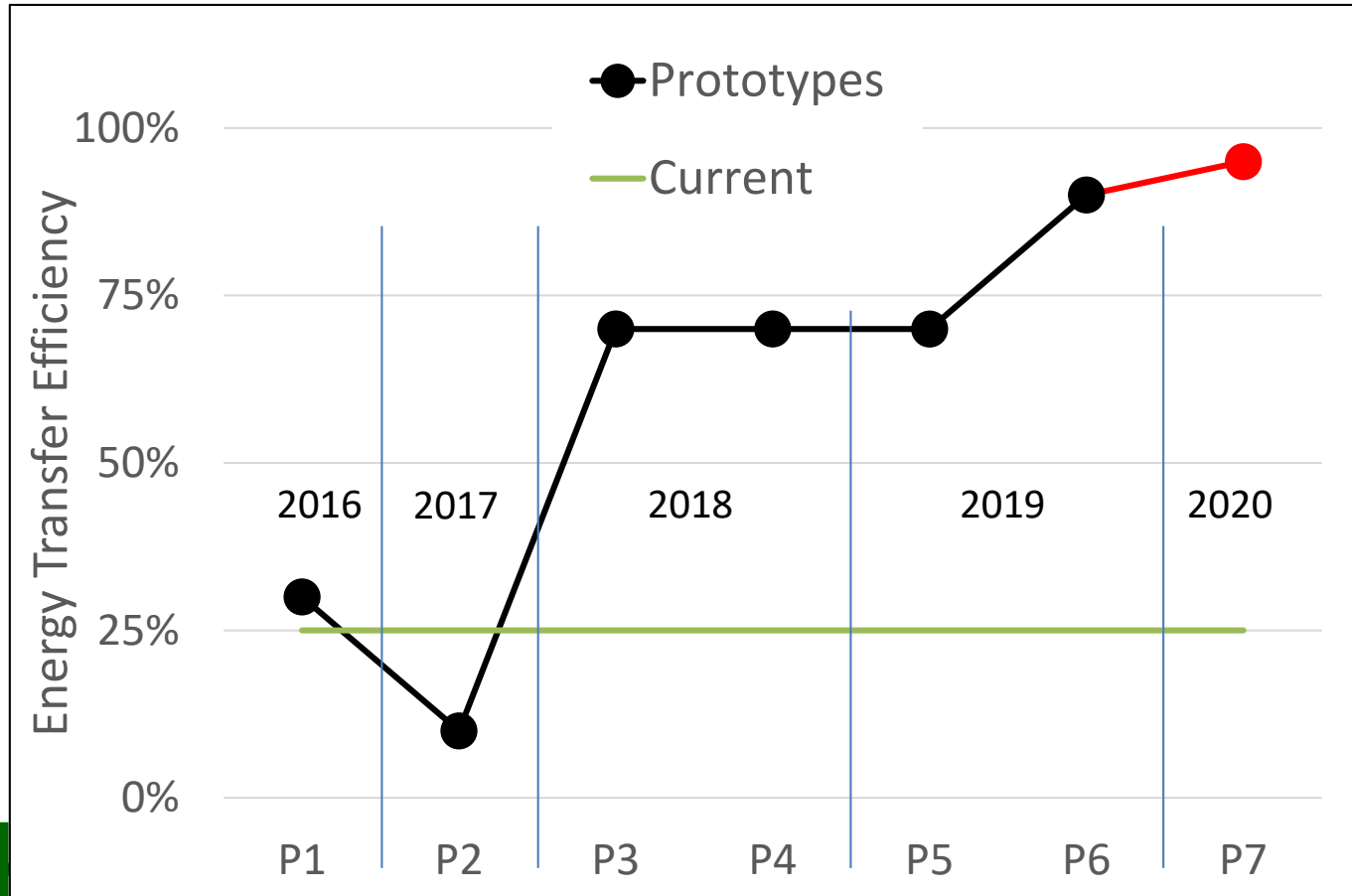

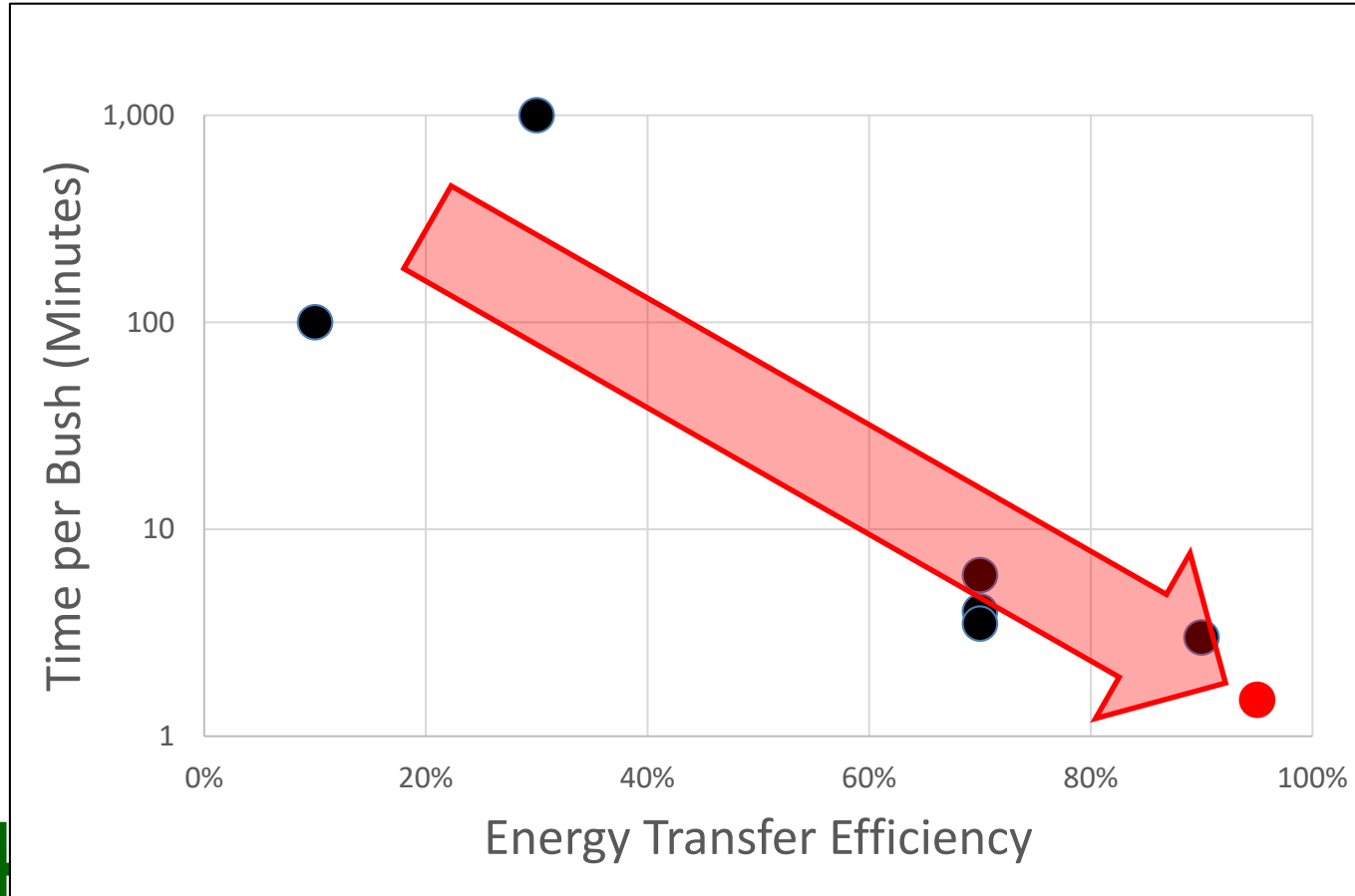



But What About Costs...?



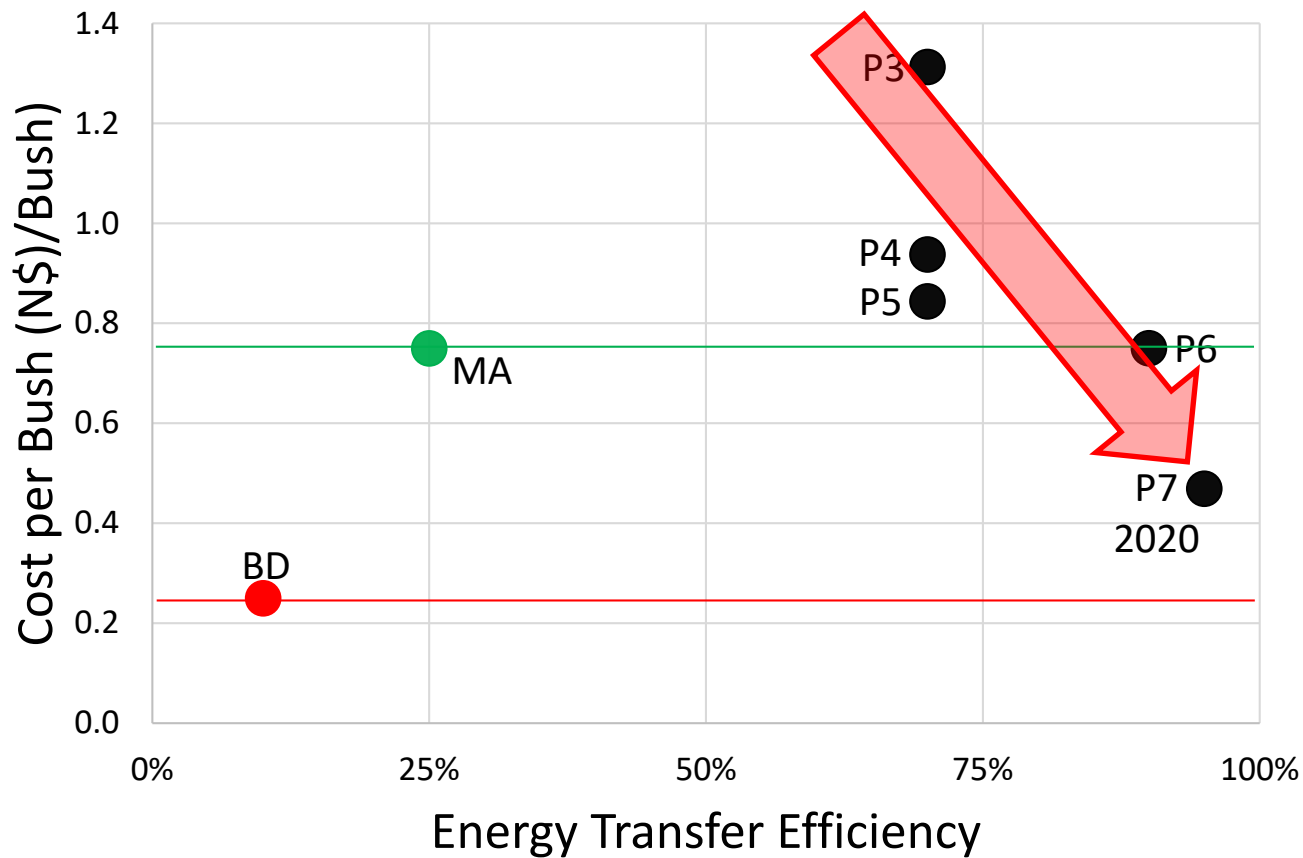

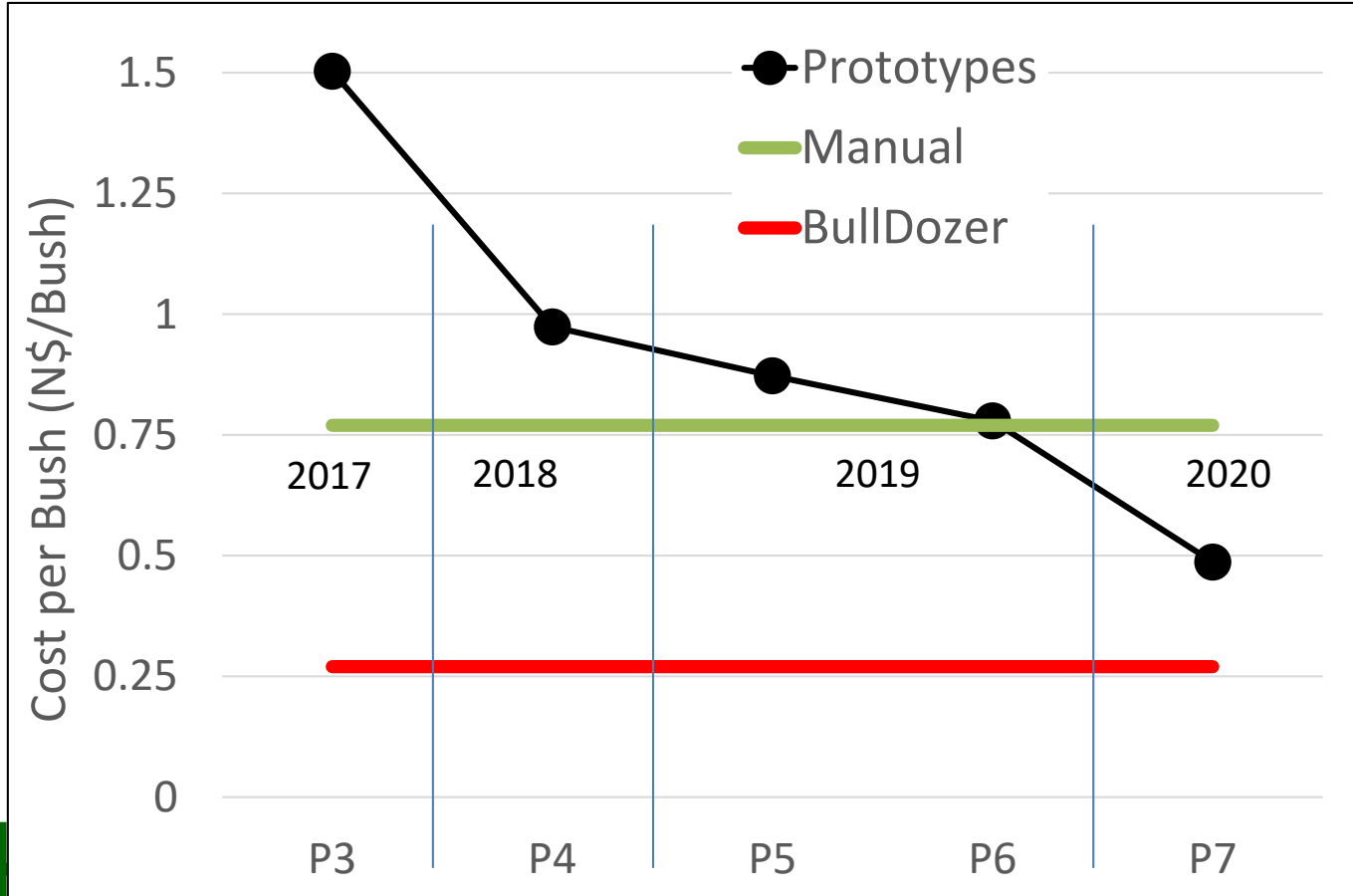

$$E = Pt \text{ kW h}$$
$$= 0.1 \text{ kW } 0.1 \text{ hr}$$
$$= 0.01 \text{ kWh}$$

$\dagger > 100 \text{ bush}$

SA \rightarrow DA

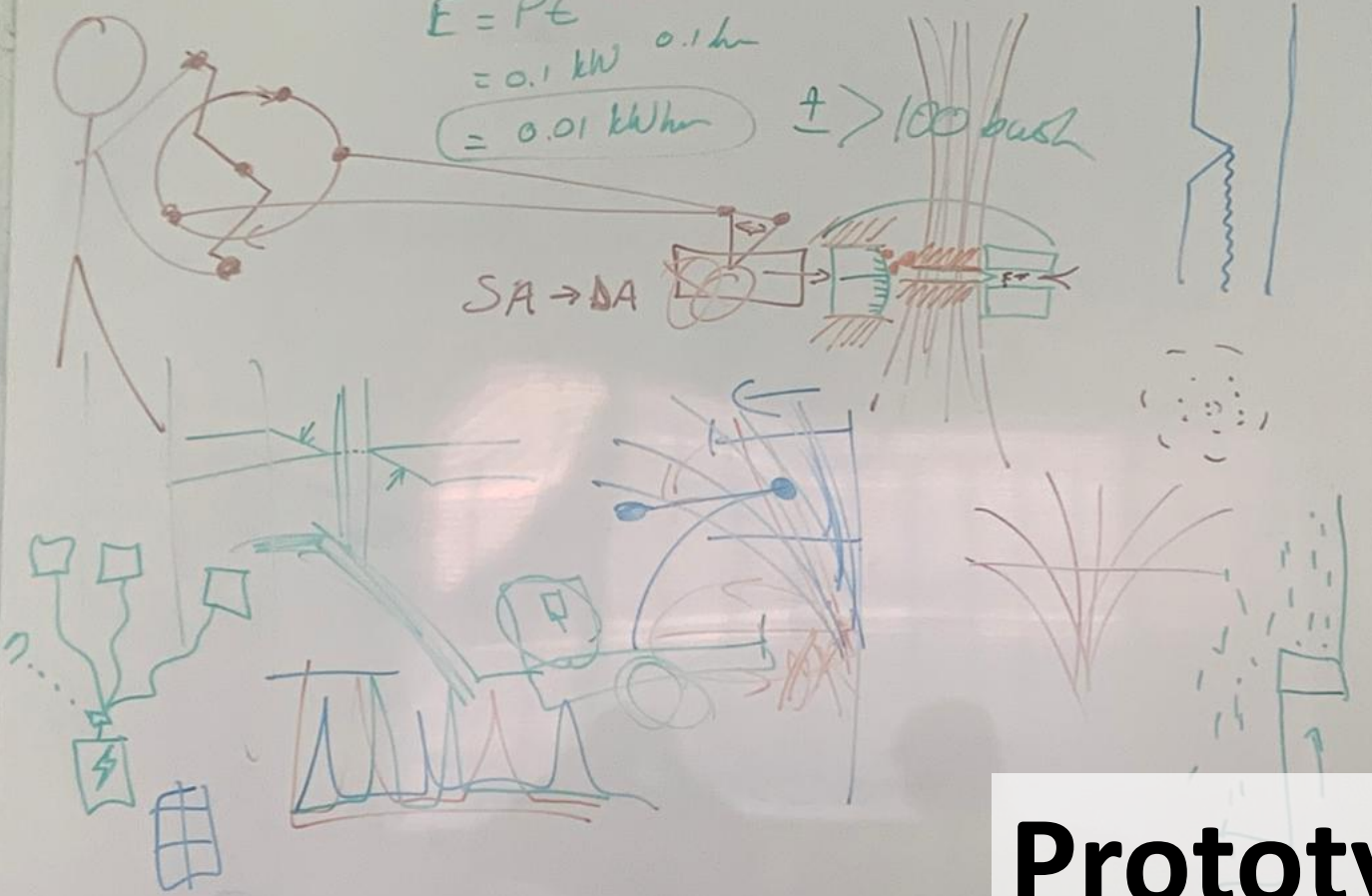

Prototype "X"

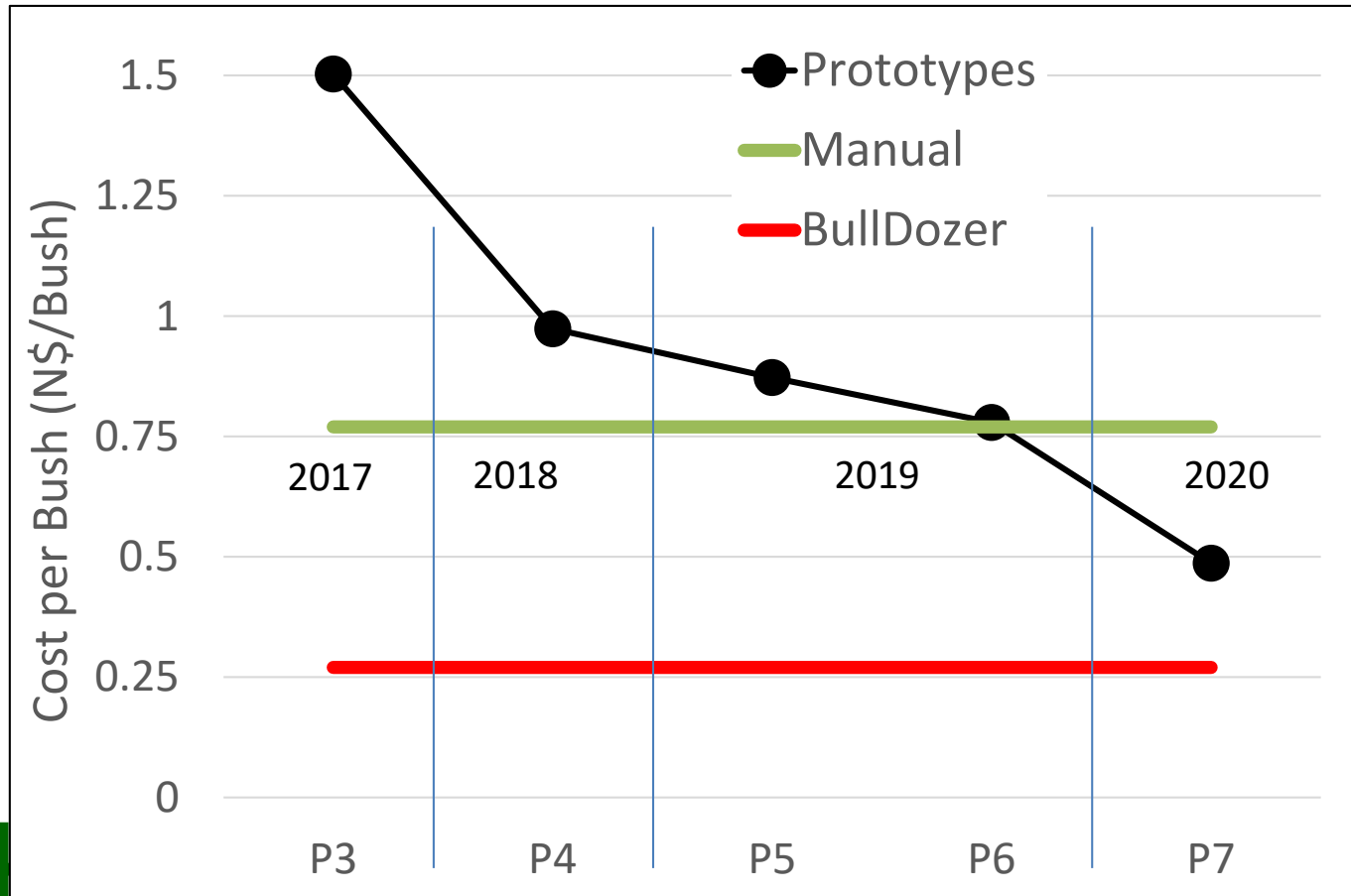

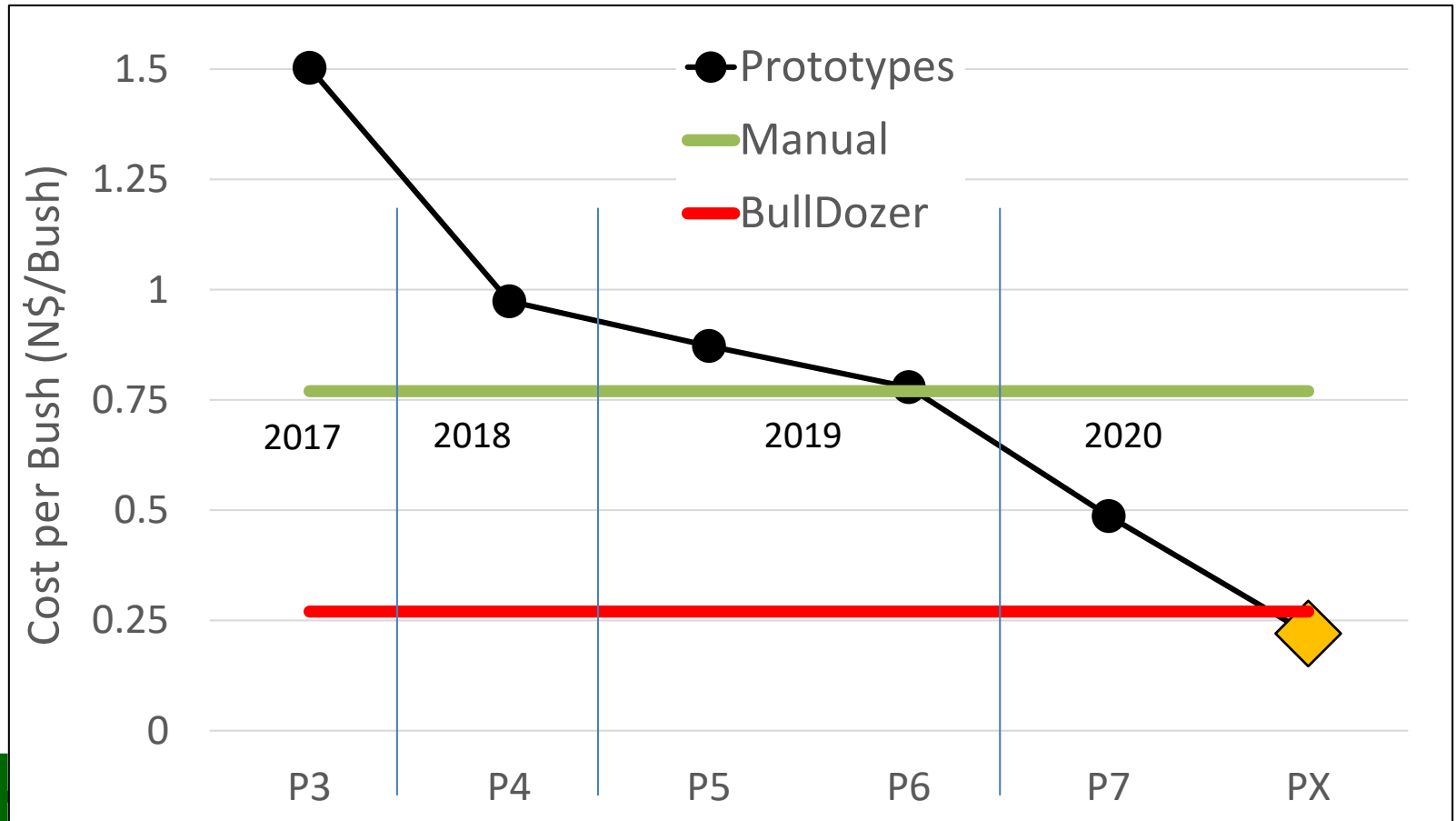

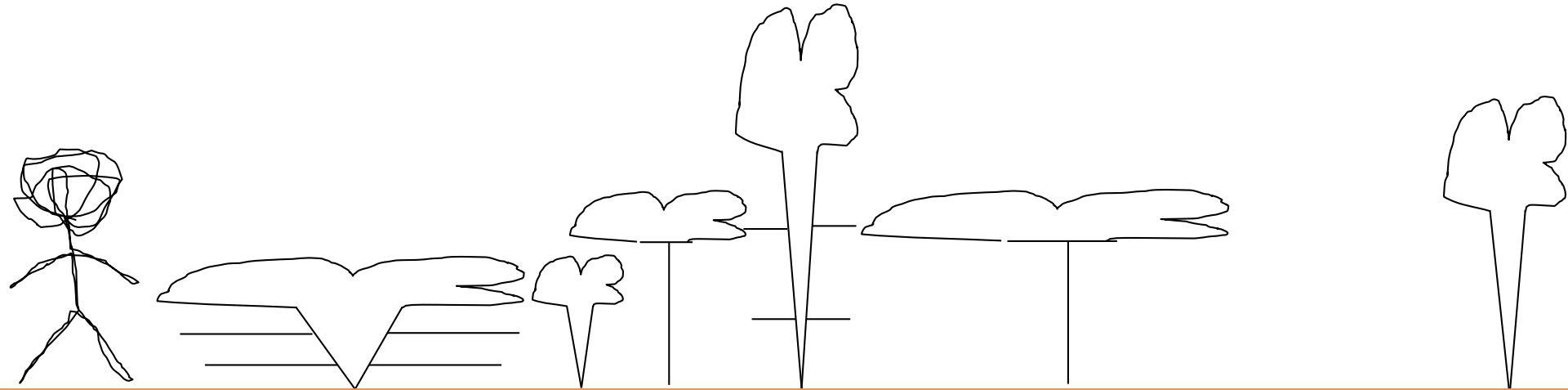

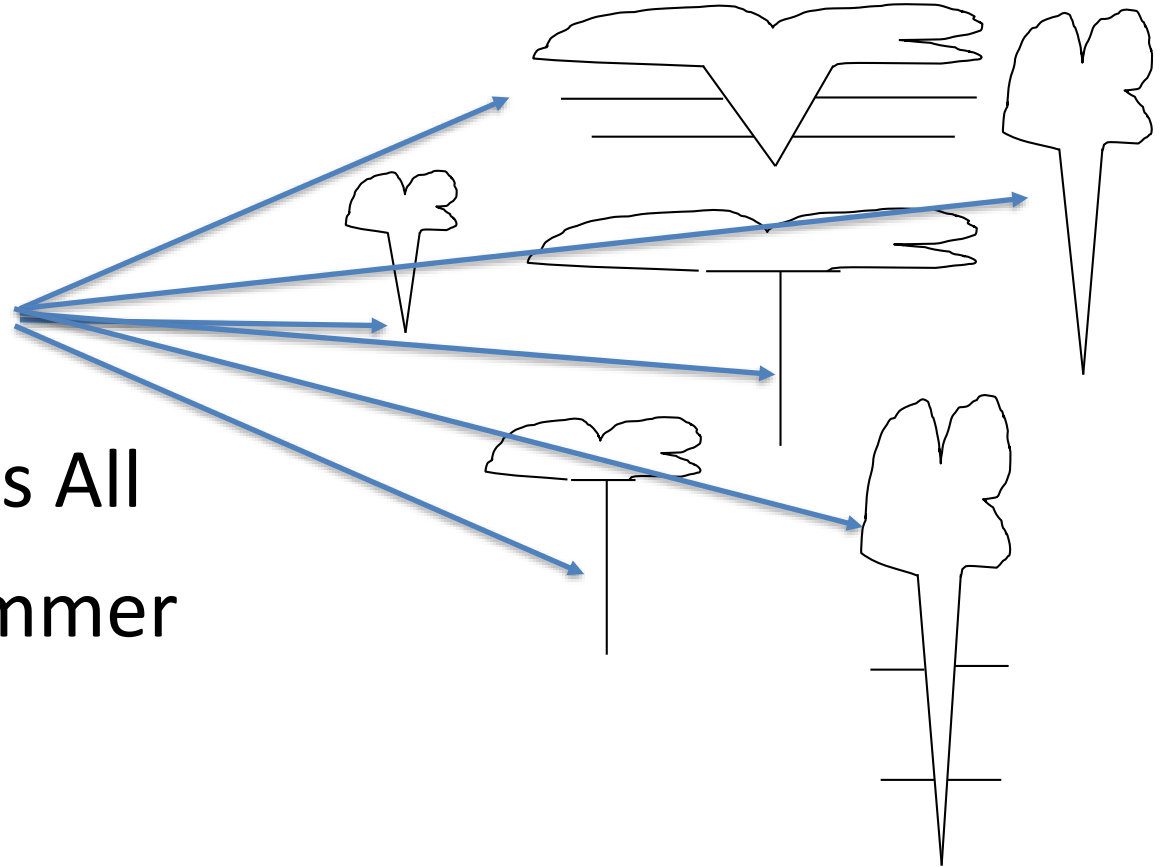
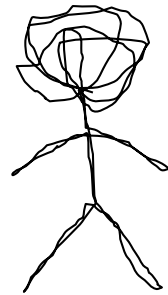

One Tool Size Fits All
Use a Larger Hammer



BUSH



german
cooperation

DEUTSCHE ZUSAMMENARBEIT



Study Different Tools

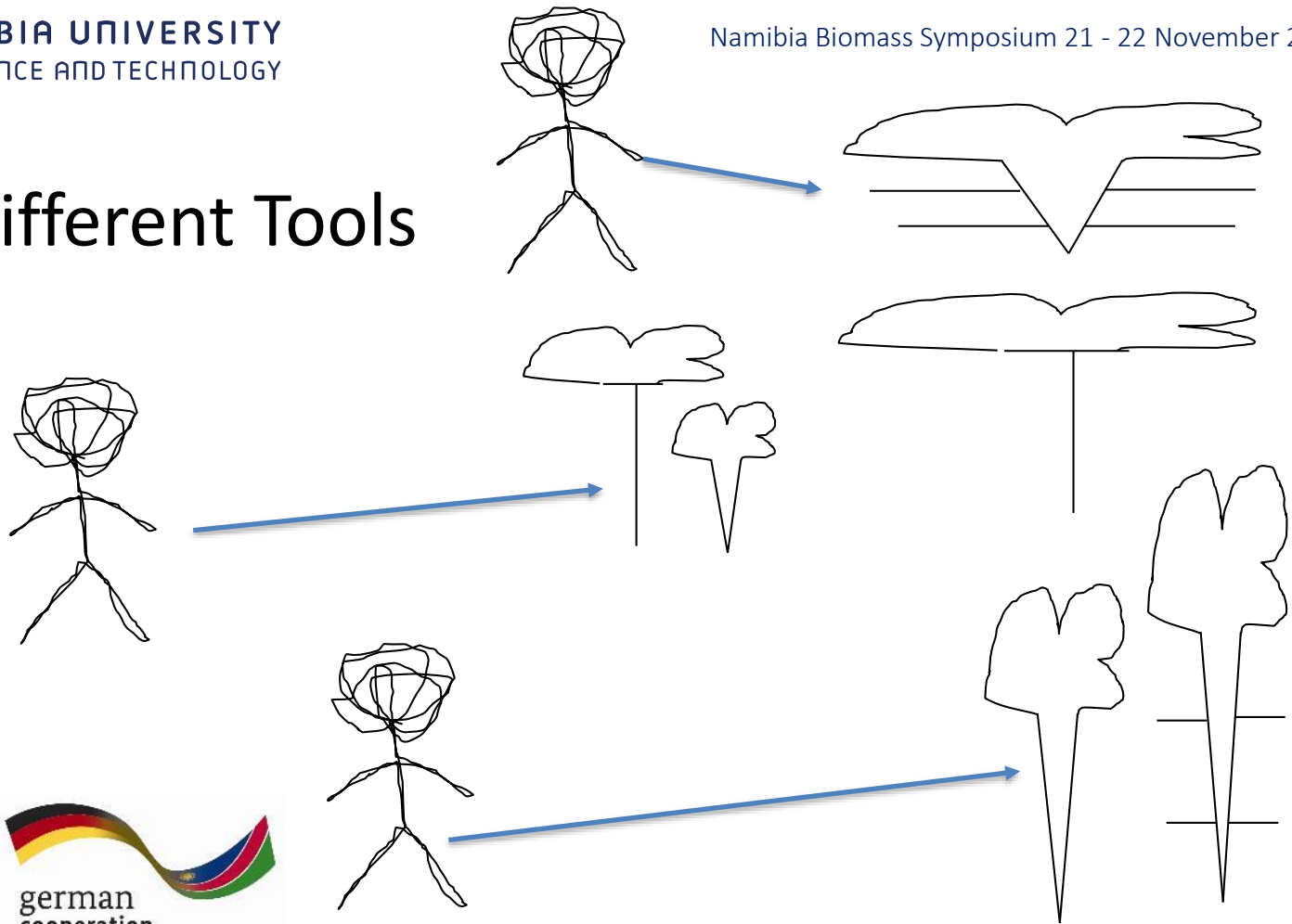

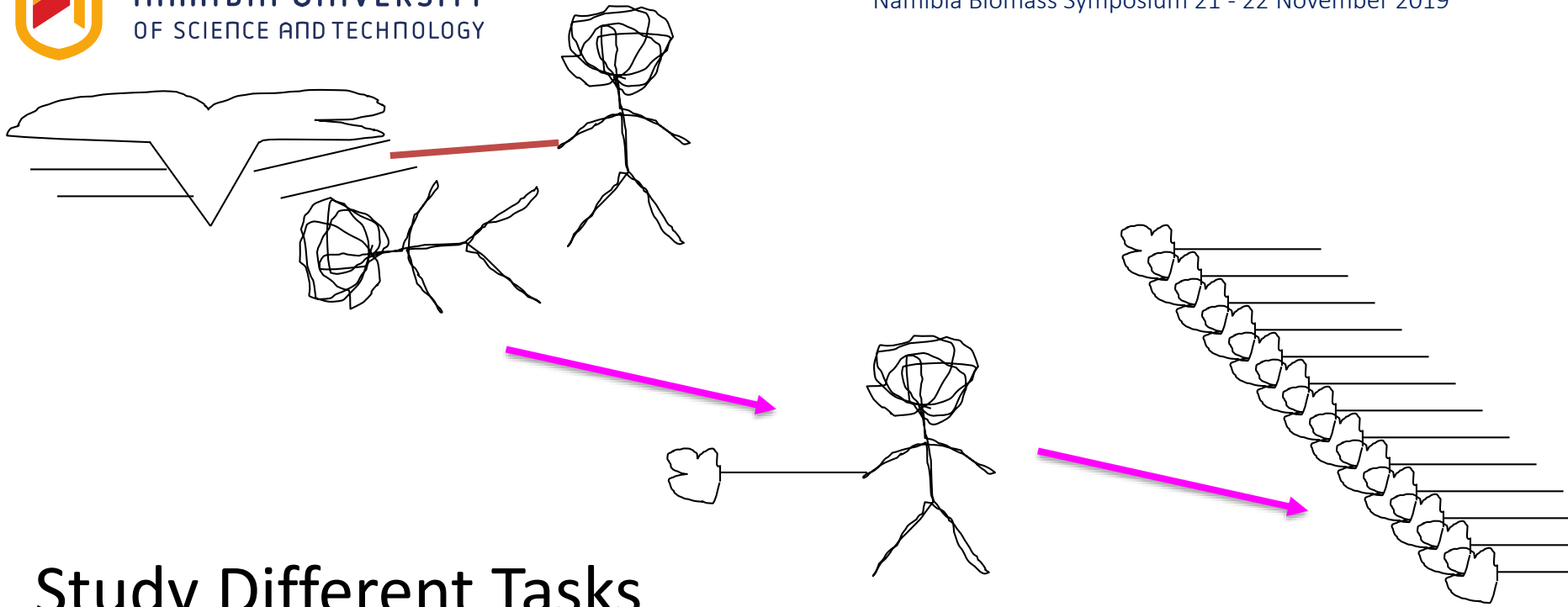

Study Different Tasks

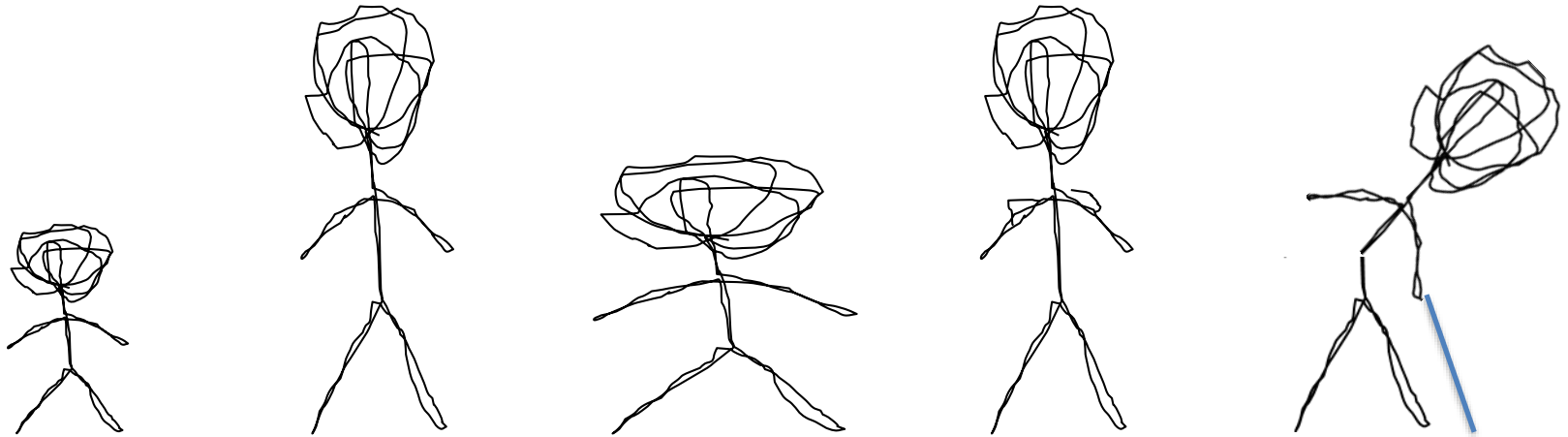

Study Different “Tools”



NAMIPIA UNIVERSITY
OF SCIENCE AND TECHNOLOGY



Thank You !

Contact Details Author : Mr Evert Strydom

T: +264 61 207 2340

C: +264 81 4844 102

E: estrydom@nust.na

W: bush.nust.na